

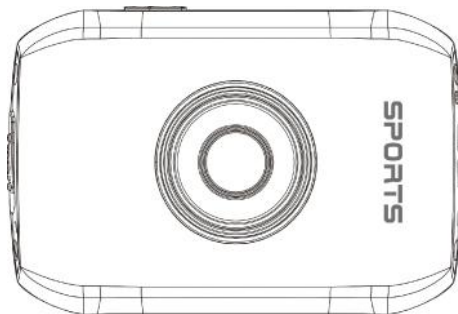

Guide d'utilisation



CSD123

ACCESSOIRES DE MONTAGE



Casier étanche



Support moto



Coque



Support
casque



Chargeur



Bande velcro



Support Ventouse

FIXATION MOTO/VELO



FIXATION CASQUE



FIXATION VOITURE



CONSEILS D'UTILISATION

- ◆ Veuillez lire attentivement les informations avant d'utiliser cette caméra vidéo pour un fonctionnement optimale, afin de prolonger sa durée de vie.
- ◆ Ne pas exposer la caméra vidéo au soleil directement, ni pointer son objectif au soleil. Sinon, le capteur d'image de la caméra vidéo peut s'endommager.
- ◆ Prenez bien soin de la caméra vidéo et évitez que l'eau ou le sable pénètrent dans le caméscope lorsqu'il est utilisé sur la plage ou l'eau.
- ◆ Garder la caméra à l'abri des matières chimiques et de la poussière. Placez-le dans un endroit sec et bien ventilé. Ne pas placer la caméra vidéo à haute température, lieu humide ou poussiéreux.
- ◆ Vérifiez si la caméra peut fonctionner normalement avant utilisation.
- ◆ Si la saleté ou la tâche s'accumule sur la caméra vidéo ou sur son objectif, utiliser un chiffon doux, propre et sec pour essuyer. Si la caméra vidéo ou son objectif est tachée de particules de sable, soufflé doucement. Ne pas utiliser de chiffon pour essuyer arbitrairement. Dans le cas contraire, il peut rayer la surface de la caméra vidéo ou son objectif.
- ◆ S'il est nécessaire de nettoyer surface de caméra, d'abord souffler la poussière accumulée sur cette surface et puis essuyez l'appareil doucement avec le chiffon ou un mouchoir applicable aux équipements optiques.

- ◆ Utilisez le produit de nettoyage de caméra vidéo pour essuyer si nécessaire. Ne pas utiliser de solvant organique pour nettoyer la caméra vidéo.
- ◆ Ne touchez pas la surface de la lentille avec les doigts.
- ◆ Veuillez sauvegarder les données si la carte mémoire à l'intérieur de ce caméscope est utilisée pour la première fois.
- ◆ Les données peuvent être perdues ou endommagées dans les circonstances suivantes :
 1. Une mauvaise utilisation de la carte mémoire.
 2. La carte mémoire est pliée, cassée ou sont endommagés.
 3. Placez sous haute température ou milieu humide ou exposer directement au soleil.
 4. Champ électrostatique ou champ électromagnétique autour de la carte mémoire.
 5. Carte mémoire retirée lorsque la caméra vidéo ou l'ordinateur est connecté dessus (c'est-à-dire au cours de la lecture, écriture et mise en forme).
 6. Touchez la surface de contact métallique de la carte mémoire avec les doigts ou les matériaux métalliques.

UTILISATION DU CASIER ÉTANCHE

- ◆ Avant de fermer le casier étanche, nettoyer le joint d'étanchéité du boîtier de la caméra, un seul cheveu ou un grain de sable peut provoquer une fuite. Vous pouvez tester en fermant le casier sans insérer la caméra. Submergez le casier complètement dans l'eau pendant environ une minute. Retirez le casier de l'eau, séchez avec une serviette, puis ouvrez le boîtier. Si tout l'intérieur est sec, vous pouvez alors utiliser le boîtier sous l'eau.
- ◆ N'oubliez pas de mettre le commutateur de mode dans votre position d'enregistrement désiré avant d'insérer l'appareil dans le casier étanche. Il n'y a aucun bouton externe pour le basculer de mode.
- ◆ Après chaque utilisation en eau salée, vous aurez besoin de rincer l'extérieur du boîtier avec l'eau non salée et puis sécher. Ne pas le faire peut éventuellement provoquer la corrosion de la charnière et l'accumulation de sel dans le joint, ce qui peut provoquer un endommagement.
- ◆ Pour nettoyer le joint d'étanchéité, rincer à l'eau et laisser sécher (sécher avec un chiffon peut endommager le joint d'étanchéité). Réinstaller le joint dans les rainures du boîtier.

DETAILS DE LA CAMERA SPORTIVE:

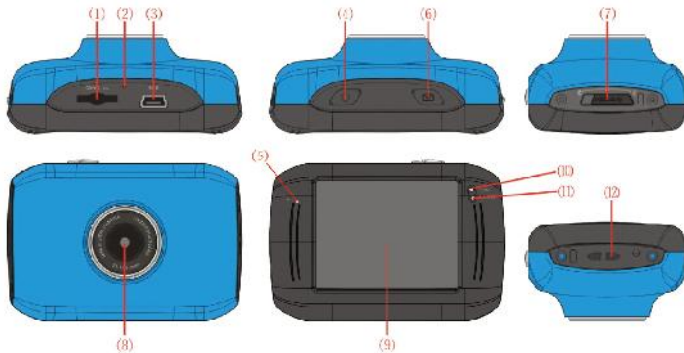

- (1) Carte mémoire
- (2) Reset
- (3) USB
- (4) On/Off
- (5) MIC
- (6) Veille

- (7) HDMI
- (8) Objectif
- (9) LCD TFT
- (10) LED de fonctionnement
- (11) LED de charge
- (12) Dragonne

UTILISATION

1. Chargement de la batterie



Connectez la caméra vidéo à l'ordinateur pour charger. Le voyant de charge s'éteint après la charge. En général, la caméra peut être entièrement chargée après 2-4 heures.

2. UTILISATION DE LA CARTE MEMOIRE

1. Enfoncez la carte mémoire dans la fente de carte mémoire jusqu'à ce qu'elle soit insérée complètement.
2. Pour retirer la carte mémoire, appuyez doucement sur l'extrémité vers l'intérieur de la carte mémoire puis la retirer.



Note: Aucune mémoire intégrée n'est disponible dans cette caméra vidéo. Assurez-vous d'insérer la carte mémoire avant utilisation.

3. ALLUMER/ETEINDRE

3.1 Allumer: Appuyez sur le bouton POWER pendant 3 secondes.

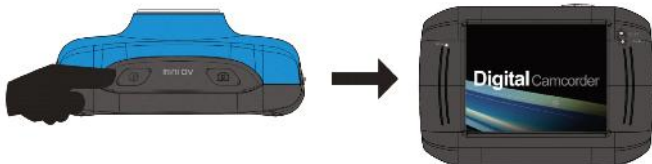

3.2. Eteindre: Appuyez sur le bouton POWER pendant 3 secondes.

Arrêt automatique : lorsque le temps d'inactivité de la caméra vidéo atteint 1 heure, l'arrêt automatique s'enclenche pour économiser la batterie.

3.3. Arrêt en cas de panne de courant : lorsque la puissance de la batterie est insuffisante, l'écran d'affichage LCD affichera l'icône de charge faible. Quand la LED devient rouge et scintille, la caméra s'éteindra automatiquement.

4. BASCULER SUR DIFFERENTS MODES

Trois modes sont disponibles pour cette caméra, photo, enregistrement vidéo et enregistrements embarqués sur véhicule. La conversion est disponible par l'intermédiaire de l'interrupteur de mode après le démarrage.

Mode prise de photo: permet de prendre une photo;

Mode enregistrement vidéo: permet d'enregistrer une vidéo;

Mode véhicule: Permet d'enregistrer en camera embarqué.

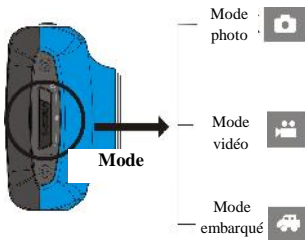

5. INDICATEUR LED

Occupé: Lorsque la caméra est occupée (par exemple, enregistrer un film, prendre des photos, automatique off-screen), le témoin occupé sera allumé.

Chargement: Quand la lumière est allumée pendant une longue période, il demande à l'utilisateur de mettre l'appareil est en charge.

6. MODE ENREGISTREMENT

Lorsque le commutateur de mode est réglé sur le mode d'enregistrement vidéo, appuyez une fois sur le bouton de l'obturateur ou cliquez sur le centre de l'écran LCD une fois pour lancer l'enregistrement; Appuyez sur le déclencheur une fois de plus si vous souhaitez arrêter l'enregistrement. La caméra arrête automatiquement l'enregistrement, lorsque la carte mémoire est pleine ou la puissance est insuffisante.

1 **00:12:18:** Cela signifie que la camera permet encore d'enregistrer 12 minutes et 18 secondes.





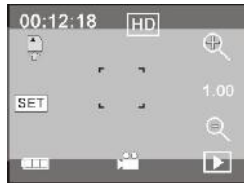

2  : Représente le mode d'enregistrement vidéo.

3  : Taille de la vidéo, appuyez pour choisir entre 720P et VGA.

4  : Signifie que la carte mémoire est insérée.





5  : Zoom numérique, appuyez pour zoomer.





- 6  : Icône zoom numérique, appuyez pour dé-zoomer.
- 7  : Appuyez pour prendre une photo ou enregistrer.
- 8  : Batterie, affiche le statut de charge.
- 9  : Affiche le détail du zoom numérique.
- 10  : Appuyez pour lancer le mode de lecture.
- 11  : Appuyez pour configurer la date et l'heure, appuyez sur  pour confirmer.

7 MODE PHOTO:

Basculez le commutateur de mode dans l'image en mode photo, appuyez sur le bouton de l'obturateur ou cliquez sur le centre de l'écran LCD une fois pour prendre une photo :

- 1 **0/1234**: Compteur, indique le nombre de photos prises / nombre total.
- 2  : Mode photo, indique que la caméra est en mode photo.
- 3  : Taille photo, appuyez pour modifier la résolution de la photo.
- 4  : Signifie que la carte mémoire est insérée.
- 5  : Zoom numérique, appuyez pour zoomer.



6  : Icône zoom numérique, appuyez pour dé-zoomer.

7  : Appuyez pour prendre une photo ou enregistrer.

8  : Batterie, affiche le statut de charge.

9  : Affiche le détail du zoom numérique.

10  : Appuyez pour lancer le mode de lecture.

11  : Appuyez pour configurer la date et l'heure, appuyez sur  pour confirmer.













8 MODE EMBARQUE:

Pour basculer en mode embarqué, appuyez sur le bouton de l'obturateur ou cliquez une fois sur l'écran pour lancer l'enregistrement. Ceci va enregistrer un segment les 5 minutes. Lorsque la carte de stockage est pleine, le premier segment de vidéo sera supprimé pour libérer de l'espace correspondant pour l'enregistrement continu.

1 00:12:18 Cela signifie que la caméra permet encore d'enregistrer 12 minutes et 18 secondes.

2  : Mode embarqué, représente le mode d'enregistrement vidéo embarqué.









- 3  : Taille de la vidéo, appuyez pour choisir entre 720P et VGA.
- 4  : Signifie que la carte mémoire est insérée.
- 5  : Zoom numérique, appuyez pour zoomer.
- 6  : Icône zoom numérique, appuyez pour dé-zoomer.
- 7  : Appuyez pour prendre une photo ou enregistrer.
- 8  : Batterie, affiche le statut de charge.
- 9  : Affiche le détail du zoom numérique.
- 10  : Appuyez pour lancer le mode de lecture.
- 11  : Appuyez pour configure la date et l'heure, appuyez sur  pour confirmer.



Note: l'écran s'éteint automatiquement pendant le processus d'enregistrement afin d'économiser de l'énergie ; appuyez sur le bouton de puissance pour faire réapparaître l'écran d'affichage.

9 MODE LECTURE:



9.1 Après la mise en marche et en état de prévisualisation, cliquez sur l'icône de lecture () dans le coin inférieur droit de l'écran LCD pour basculer vers le mode de lecture :

- 1  : Signifie que le fichier actuel est au format AVI.
- 2  : Signifie qu'il y a 1 fichier dans le dossier / 1 fichier au total.
- 3  : Nom du dossier (comme: I:\DCIM\100MEDIA
I: est le nom de lecteur de la caméra).
- 4  : Passe au fichier suivant.
- 5  : Reviens au fichier précédent.
- 6  : Permet d'effacer le fichier sélectionné.
- 7  : Permet de visualiser le fichier sélectionné.
- 8  : Permet de basculer entre les modes photo et vidéo.



9.2 Lire une vidéo enregistrer:



Appuyez sur  pour faire pause, appuyez sur  pour faire une recherche rapide.

9.3 Supprimer un fichier:

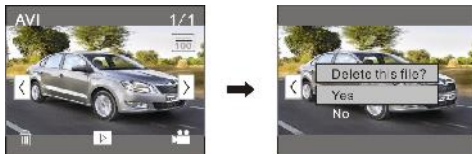

Appuyez sur YES pour supprimer le fichier, appuyez sur NO pour annuler la suppression.

CONNECTER LA CAMERA A VOTRE ORDINATEUR

La caméra est fournie avec la fonction plug-and-play. Connectez le périphérique à l'ordinateur avec le câble USB en état de marche, la caméra bascule automatiquement dans le mode disque dur amovible.

Icône du disque amovible apparaît sur « mon ordinateur ». Vos photos/vidéos sont enregistrés dans le dossier I:\DCIM\

SÉCURITÉ – ENVIRONNEMENT



Votre produit STOREX a été testé en laboratoire ; il est conforme aux directives Européennes correspondant au marquage CE en vigueur au moment de sa commercialisation.



Une traçabilité des composants de votre produit STOREX a été réalisée ; elle nous a démontré la conformité du produit à la directive environnementale (RoHS) en vigueur au moment de sa commercialisation.



En fin de vie, ne pas jeter le produit à la poubelle mais le ramener au distributeur ou à votre déchetterie qui se chargera de faire passer le produit dans une filière de recyclage des déchets électriques, électromécaniques et électroniques (DEEE).

ENREGISTREMENT DE LA GARANTIE

Afin de faciliter votre prise en charge lors d'un éventuel entretien avec notre équipe de support, nous vous invitons à enregistrer la garantie de votre produit sur notre site Web à l'adresse : <http://garantie.storex.eu>

En cas de panne, veuillez contacter votre revendeur pour faire réparer votre produit sous garantie, ou veuillez adresser votre demande par courrier électronique à l'adresse : support@storex.eu

ou par téléphone au

France : 01 55 85 82 00 (support.fr@storex.eu)

Portugal : 707 20 14 20 (apoio.pt@storex.eu)

Espagne : 902 110 572 (soporte.es@storex.eu)

Angleterre : (support.uk@storex.eu)

X'TREM 

by  **STOREX**



USER MANUAL

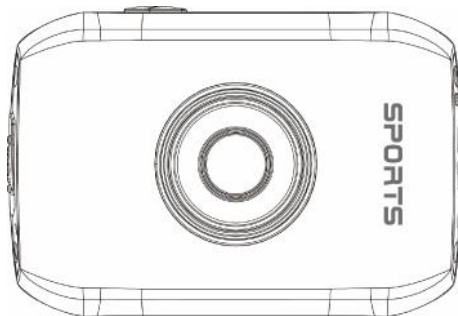

CSD123

Mounting Accessories



Waterproof Case



Handlebar
Seatpost
Mount



Shield



Helmet Mount



Car Charger



Helmet Belt



Suction Cup Mount

Quick User Guide

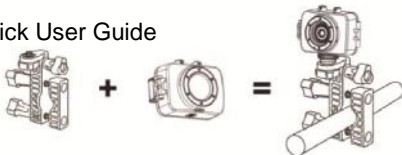

HELMET EDITION



CAR DRIVING RECORDER EDITION

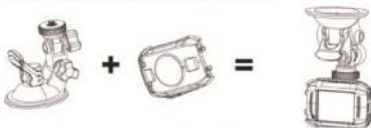

ANNOUNCEMENTS

Please read the Announcements carefully before using this video camera for proper and safe operation, so as to bring its optimum performance into play and extend its service life.

- ◆ Do not expose the video camera to sunshine directly, nor point its lens to sunlight. Otherwise, the image sensor of the video camera may be damaged.
- ◆ Take good care of the video camera and prevent water or sand particles from entering the video camera when it is used on the beach or water, because water, sand particles, dust or component containing salt may damage the video camera.
- ◆ Keep the video camera contaminated free of dust and chemical materials. Place it in a cool, dry and well ventilated place. Do not place the video camera in a high temperature, moist or dusty place.
- ◆ Please check if the video camera can operate normally before use.
- ◆ If dirt or stain is accumulated on the video camera or on its lens, use soft, clean and dry rag to wipe it away gently. If the video camera or its lens is stained with sand particles, blow them away gently. Do not use cloth to wipe arbitrarily. Otherwise, it may scratch the surface of video camera or its lens.
- ◆ If it is required to clean camera surface, firstly blow away the sand dust accumulated on this surface, and then wipe the camera gently with rag or tissue applicable to optical equipments. Please use the cleaning

agent of video camera for wiping if necessary. Do not use organic solvent to clean the video camera.

- ◆ Do not touch the lens surface with fingers.
- ◆ Please back up the data if the memory card inside this video camera is used for the first time.
- ◆ The externally installed memory-cards are manufactured from precise electronic components. Data may be lost or damaged under the following circumstances:
 1. Improper use of the memory card.
 2. The memory card is bent, dropped or collided.
 3. Place it under high temperature or moist environment or expose to sunshine directly.
 4. Electrostatic or electromagnetic field exists around the memory card.
 5. This memory card is taken out or power supply is interrupted when this video camera or computer is connected to the memory card (i.e. during reading, writing and formatting).
 6. Touch the metal contact surface of the memory card with fingers or metal materials.

WATERPROOF CASE USING NOTICE

- ◆ Before sealing the waterproof case, keep the camera housing's rubber seal clean, a single hair or grain of sand can cause a leak. You can test by closing the case without inserting the camera. Submerge the case completely in water for about a minute. Remove the case from the water, dry off its exterior with a towel, then open the case. If the entire interior is dry, the case is safe for use under water.
- ◆ Remember to put the Mode Switch in your desired recording position before inserting the camera in the waterproof case. There is no external button for the Mode Switch.
- ◆ After every use in salt water you will need to rinse the outside of the housing with non-salt water and dry. Not doing this can eventually cause corrosion of the hinge pin and salt buildup in the seal, which can cause failure.
- ◆ To clean the seal, rinse in fresh water and shake dry (drying with a cloth may cause lint to compromise the seal). Re-install the seal into the grooves in the backdoor of the housing.

INTRODUCTION TO APPEARANCE AND KEYPAD

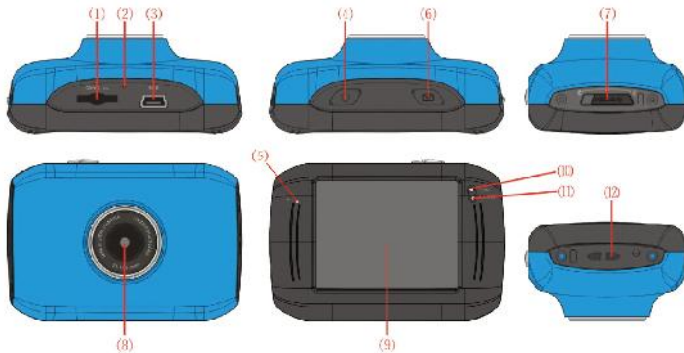

- (1)Memory card slot
- (2)Reset
- (3)USB slot
- (4)Power button
- (5)MIC
- (6)Shutter button

- (7)Mode Switch:
- (8)Lens
- (9)LCD TFT
- (10)Working Indicator Light
- (11)Indicator Light for charging
- (12)Wrist strap eyelet

USAGE

1. Charge the built-in lithium battery



Connect the video camera with computer for charging in the shutdown state. The indicator light for charging is on at this time and will be off after charging. In general, it can be fully charged after 2-4 hours.

2. USE OF MEMORY CARD

1. Push the memory card into the card slot according to the concave lettering beside the slot of memory card till it is completely inserted.
2. To take out the memory card, gently press the end of the memory card inward and it will pop up.



Note: No built-in memory is available in this video camera. Make sure to insert memory card before using.

3. STARTUP/SHUTDOWN

3.1 Startup: Press the POWER button for 3 seconds, the screen is displayed and the camera is on.

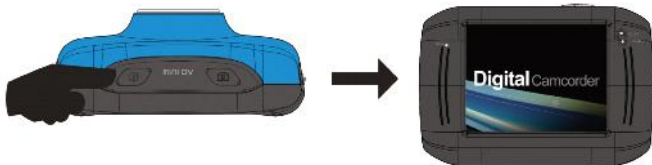

3.2. Shutdown: Press the POWER Key, and the camera will be shut down. .

Automatic shutdown: when the idle time of the video camera reaches the time for automatic shutdown, it will be shut down automatically to save power. The default time of this camera for automatic shutdown is 5 minutes.

3.3. Shutdown in case of power shortage: when the power of the battery is insufficient, the LCD display screen will display the low power icon. Please charge it in time. When indicate light turns red and flickering, the video camera will be shut down automatically.

4. CONVERSION BETWEEN FUNCTION MODES

Three modes are available for this video camera, i.e. picture taking mode, video recording mode and vehicle-mounted mode. Conversion is available via the mode switch after startup.

Picture taking mode: pictures can be taken;

Video recording mode: video can be recorded;

Vehicle-mounted mode: videotape can be recorded.

(one section every 5 minutes)

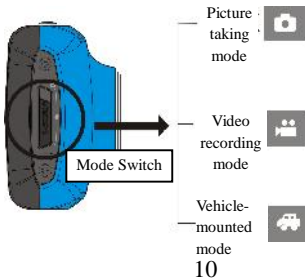

5. INDICATOR LIGHT

Busy light: when the camera is busy (such as, recording a film, taking photos, automatic off-screen), the busy light will be on.

Charging light: when the light is on for a long time, it prompts the user that the camera is charging.

6. VIDEO RECORDING MODE

When the mode switch is turned to video recording mode, press the shutter button once or click the LCD center once to begin recording under previewing state; press the shutter button once again if you want to stop recording, and the camera will also stop recording, automatically when the memory card is full or the power is insufficient-







1 **00:12:18:** Timer means that video recording can still last for 12 minutes and 18 seconds.

2  : mode icon, represents that the video camera is in video recording mode.

3  : videoing size, clicks this icon and you can choose 720P/VGA.

4  : means that the memory card is inserted at present.





- 5  : digital zoom icon, click it and enlarge it.
- 6  : digital zoom icon, click and minify it.
- 7  : visual shutter, touch this visible frame for taking photos or recording.
- 8  : battery icon, represents the power status of the battery.
- 9  : represents the status of digital zoom.
- 10  : click this icon to switch to the playback mode.
- 11  : click this icon to set the date and time, finished setting and press Shutter key to confirm.

7 PICTURE TAKING MODE:

1 **0/1234**: Counter, indicating current number of photos taken already /number of photos to be taken.

2  : mode I con, indicating that the camera is in photo taking mode.

3  : video size, click this icon to select the photo resolution.

4  : means that the memory is been inserted at present.

5  : digital zoom icon, click it to enlarge.

6  : digital zoom icon, click it to minify.

7  : visual shutter, touch this visible frame for taking photos or recording.

8  : battery icon, indicates the power status of the battery.

9  : represents the status of digital zoom.

10  : click this icon to switch to the playback mode.

11  : click this icon to set the date and time, finished setting and press Shutter key to confirm.





8 VEHICLE-MOUNTED MODE:

1 00:12:18 timer, indicating that the camera can still record for 12 minutes and 18 seconds.

2  : mode icon, representing that the camera is in vehicle-mounted mode.

3  : video size, click this icon to select 720P, VGA.

4  : represents that the memory card has been inserted.

5  : digital zoom icon, click it to enlarge.

6  : digital zoom icon, click it to minify.

7  : visual shutter, touch this visible frame for taking photos or recording.

8  : battery icon, representing the current power status of the battery.

9  : represents the status of digital zoom.

10  : click this icon to switch into the playback mode.









11  : click this icon to set the date and time, finished setting and press Shutter key to confirm.



9 PLAYBACK MODE:

9.1 After starting up and entering the previewing state, click the playback icon () at the lower right corner of the LCD to switch to the playback mode:



Click

- 1  : represents that the current file is an AVI video file.
- 2  : represents that there is one file in the current folder/one file in total.
- 3  : current folder name (such as: I:\DCIM\100MEDIA
I: is the movable disk of the device).
- 4  : Means that clicking can select files frontwards.
- 5  : Means that clicking can select files backwards.
- 6  : Means that clicking can activate to confirm the deletion of the current file picture.
- 7  : Means that clicking can play the current movie clips.
- 8  : Means that clicking can switch back to the previous photo mode (video mode).



9.2 Movie clips playing:



Click  to pause playing, click  to play forward, and click  to play backward.

9.3 File deletion:

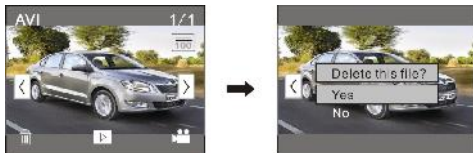

Click YES to delete the current file immediately, or click NO to cancel the request of deletion.

APPLY ON THE PERSONAL COMPUTER

Connect to personal computer

The camera is provided with the plug and play function. Connect the device to the computer with USB line under turning-on state, then it will be switched into the movable hard disk mode.

Icon of movable disk will appear on the window of “my computer”. Photos/videos you have taken are saved in folder I:\DCIM\100MEDIA (I is the movable disk of this device) in the movable disk. Files recorded in vehicle-mounted mode are saved in I:\DCIM\RECORDER.

SAFETY-ENVIRONMENT



Your STOREX product has been laboratory tested; it complies with European guidelines corresponding to the CE labelling in force at the time of its launch.



Your STOREX product's components are traceable; this demonstrates the product's compliance to environmental guidelines (RoHS) in force at the time of its launch.



Once the product has reached the end of its lifespan, don't throw it in a dustbin. Return it to the retailer or bring it to a rubbish heap, to ensure the product is properly disposed of via a waste electrical and electronic equipment (WEEE) channel.

WARRANTY REGISTRATION

In order to facilitate the management of your issue, should you contact our support team, we invite you to register your tablet guarantee on our website at the following address: <http://garantie.storex.eu>

For repairing, contact your dealer to repair your tablet under guarantee, or send your request via email to the following address: support@storex.eu

or by phone at:

France: 01 55 85 82 00 (local call charge to Paris)

Spain: 902 110 572 (soporte.es@storex.eu)

Portugal: 707 20 14 20 (apoio.pt@support.eu)

England: (support.uk@storex.eu)

X'TREM 

by



STOREX



Guía de Inicio Rápida

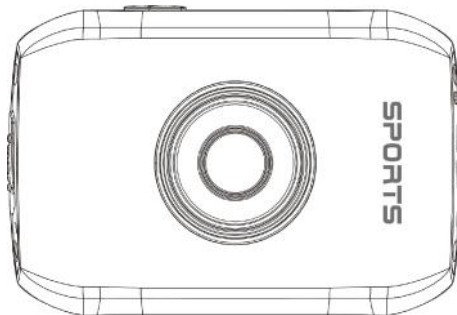

CSD123

Accesorios incluidos



Caja sumergible



Fijación barra



Soporte para casco



Banda de velcro para casco

Fijación Moto/VTT

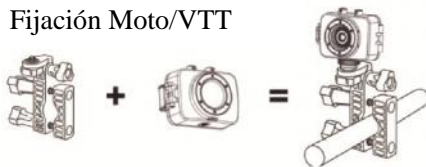

Fijación Casco



Consejos de Utilización

- ◆ Lea atentamente la información antes de utilizar esta cámara de vídeo para un funcionamiento óptimo, con el fin de alargar su duración.
- ◆ No exponer la cámara de vídeo directamente al sol, ni dirigir su objetivo hacia el sol. Sino el captor de imagen puede dañarse.
- ◆ Evite que el agua o la arena penetren durante su utilización en plaza o agua.
- ◆ Mantenga la cámara alejada de materiales químicos y del polvo. Guárdelo en un lugar seco y bien ventilado. No exponga la cámara a altas temperaturas, lugares húmedos o llenos de polvo.
- ◆ Verifique si la cámara funciona normalmente antes de su utilización.
- ◆ Si la suciedad se acumula sobre la cámara o el objetivo, utilice un trapo suave, limpio y seco para limpiar. Si la cámara o el objetivo tiene partículas arenosas, sople suavemente. No utilizar trapos para limpiarla arbitrariamente, en el caso contrario puede rayarse la cámara o el objetivo.
- ◆ Si es necesario limpiar la superficie de la cámara, primero sople el polvo acumulado y luego limpie suavemente con un trapo o un pañuelo para equipos ópticos.
- ◆ Utilice el producto de limpieza específico para limpiar si es necesario. No utilizar solventes orgánicos.

- ◆ No toque la superficie del lente con los dedos.
- ◆ Guarde los archivos almacenados en su tarjeta de memoria si es la primera vez que utiliza la cámara.
- ◆ Los archivos pueden perderse o dañarse en los siguientes casos:
 1. Una mala utilización de la tarjeta de memoria.
 2. La tarjeta de memoria se ha doblado, roto o dañado.
 3. Expuesta a altas temperaturas, humedad o al sol.
 4. Campos electromagnéticos o electrostáticos cerca de la tarjeta de memoria.
 5. Tarjeta de memoria retirada mientras la cámara o el ordenador están conectados (en curso de lectura, escritura o formateo).
 6. Tocar la superficie metálica de la tarjeta de memoria con los dedos o con materiales metálicos.

Utilización de la caja sumergible

- ◆ Antes de cerrar la caja sumergible, limpiar las juntas de la caja, un solo cabello o grano de arena podrían provocar que el agua penetre. Pruebe cerrando la caja sin insertar la cámara. Sumerja la protección completamente en el agua durante un minuto. Retírela del agua, séquela con un paño, luego abra la caja. Si

el interior está seco, ahora puede utilizarlo normalmente.

- ◆ No olvide de poner el conmutador en modo grabación antes de insertar la cámara en la caja sumergible. No hay ningún botón externo para bascular en los diferentes modos.
- ◆ Luego de cada utilización en agua sucia, limpie el exterior de la caja sumergible con agua limpia y luego séquela. No hacerlo puede provocar algún tipo de daño.
- ◆ Para limpiar la junta, hacerlo con agua y dejar secar (secar con un trapo puede dañar las juntas). Volver a poner las juntas en las ranuras de la caja.

Detalles de la cámara deportiva:

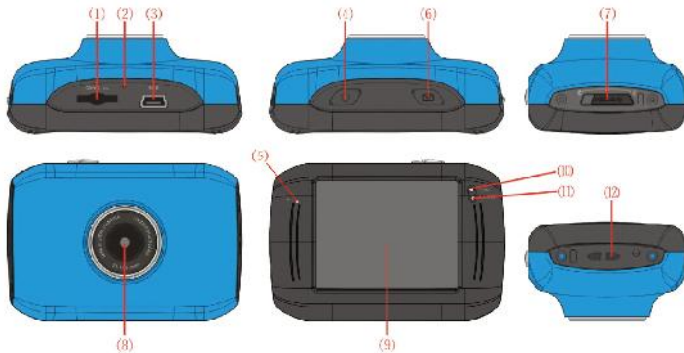

- (1) Tarjeta de memoria
- (2) Reset
- (3) USB
- (4) On/Off
- (5) MIC
- (6) Stand by

- (7) HDMI
- (8) Objetivo
- (9) LCD TFT
- (10) LED de funcionamiento
- (11) LED de carga
- (12) Correa

Utilización

1. Recarga de la batería



Conecte la cámara al ordenador para cargarla. El indicador de carga se apagará una vez recargada. En general, la cámara puede cargarse completamente entre 2 a 4 horas.

2. Utilización de la tarjeta de memoria

1. Introduzca la tarjeta de memoria en la ranura hasta que esté completamente en el interior.
2. Para retirarla, presione suavemente en la tarjeta hacia adentro y luego retírela.



Note: Ninguna tarjeta de memoria integrada viene en la cámara. Asegúrese de insertar la tarjeta de memoria antes de cada uso.

3. Encender/Apagar

3.1 Encender: Presione el botón POWER durante 3 segundos.

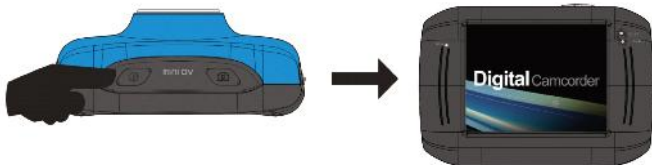

3.2. Apagar: Presione el botón POWER durante 3 segundos.

Apagado automático: Si el tiempo de inactividad es de 1 hora, el apagado automático va a ponerse en marcha para economizar la batería.

3.3. Apagado a causa de problemas de energía: Cuando la batería es insuficiente, la pantalla LCD mostrará el ícono de carga baja. Cuando el LED se vuelva rojo y parpadee, la cámara se apagará automáticamente.

4. Cambiar los diferentes modos

Tres modos están disponibles en esta cámara, foto, grabación de vídeo y grabación a bordo del vehículo. La conversión está disponible por intermedio del interruptor de modo después del encendido.

Modo de toma de fotos: permite hacer fotos;

Modo de grabación de vídeo: permite la grabación de vídeo;

Modo vehículo: permite la grabación a bordo de un vehículo.

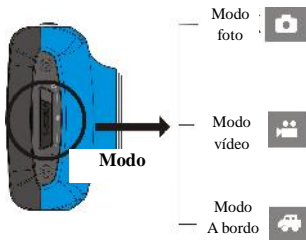

5. Indicador LED

Ocupado: Cuando la cámara está ocupada (por ejemplo, grabación de vídeo, toma de fotos, off-screen automático), el indicador ocupado se encenderá.

Carga: Cuando la luz está encendida durante un largo período, solicita al usuario de poner la cámara en carga.

6. Modo grabación

Cuando el conmutador está en el modo de grabación de vídeo, presione una vez el botón del obturador o toque el centro de la pantalla LCD una vez para lanzar la grabación. Presione una vez más si desea parar la grabación. La cámara dejará de grabar automáticamente, si la tarjeta de memoria está llena o la batería es insuficiente.

1 **00:12:18:** Esto significa que la cámara permite la grabación durante 12 minutos y 18 segundos.







2  : Representa el modo de grabación de vídeo.

3  : Tamaño del vídeo, presionar para elegir 720P y VGA.

4  : Significa que la tarjeta de memoria ha sido insertada.





5  : Zoom numérico, presione para aumentar.









- 6  : Ícono de zoom numérico, presione para disminuir.
- 7  : Presione para tomar una foto o grabar.
- 8  : Batería, muestra el estatus de carga.
- 9  : Muestra el detalle del zoom numérico.
- 10  : Presione para comenzar el modo lectura.
- 11  : Presione para configurar la fecha y la hora, presione  para confirmar.

7 Modo Foto:

Cambie a modo foto, presione el botón del obturador o toque el centro de la pantalla LCD una vez para tomar una foto:



- 1 **0/1234**: Indique la cantidad de fotos tomadas/número total.
- 2  : Modo foto, indica que la cámara está en modo fotografía.
- 3  : Tamaño de la foto, presione para modificar la resolución de la foto.
- 4  : Significa que la tarjeta de memoria ha sido insertada.
- 5  : Zoom numérico, presione para aumentar.









- 6  : Ícono de zoom numérico, presione para disminuir.
- 7  : Presione para tomar fotos o grabar.
- 8  : Batería, muestra el estatus de carga.
- 9  : Muestra el detalle del zoom numérico.
- 10  : Presione para comenzar el modo lectura.
- 11  : Presione para configurar la fecha y la hora, presione  para confirmar.



8 Modo a bordo:

Para cambiar en modo a bordo, presione el botón del obturador o toque una vez la pantalla LCD para comenzar la grabación. Esto grabará un segmento cada 5 minutos. Cuando la tarjeta de memoria está llena, el primer segmento de vídeo será eliminado para liberar espacio correspondiente para la grabación continua.

- 1 00:12:18 Esto significa que la cámara puede grabar 12 minutos y 18 segundos.
- 2  : Modo a bordo, representa el modo de grabación a bordo.
- 3  : Tamaño del vídeo, presione para elegir entre 720P y VGA.

- 4  : Significa que la tarjeta de memoria ha sido insertada.
- 5  : Zoom numérico, presione para aumentar.
- 6  : Ícono de zoom numérico, presione para disminuir.
- 7  : Presione para tomar fotos o grabar.
- 8  : Batería, muestra el estatus de carga.
- 9  : Muestra el detalle del zoom numérico.
- 10  : Presione para comenzar el modo lectura.
- 11  : Presione para configurar la fecha y la hora, presione  para confirmar.











Nota: la pantalla se apagará automáticamente durante el proceso de grabación con el fin de economizar la energía; presione el botón de potencia para hacer aparecer la pantalla de muestra.

9 Modo lectura:

9.1 Luego de la puesta en marcha y en estado de previsualización, toque el ícono de lectura () en la esquina

inferior derecha de la pantalla LCD para cambiar al modo de lectura:

- 1  : Significa que el archivo actual está en formato AVI.
- 2  : Significa que hay 1 archivo en la carpeta/ 1 archivo en total.
- 3  : Nombre del archivo (como: I:\DCIM\100MEDIA I: es el nombre de lectura de la cámara).
- 4  : Pasar al archivo siguiente.
- 5  : Volver al archivo precedente.
- 6  : Permite suprimir el archivo seleccionado.
- 7  : Permite visualizar el archivo seleccionado.
- 8  : Permite cambiar entre el modo foto y vídeo.



9.2 Reproducir un vídeo grabado:

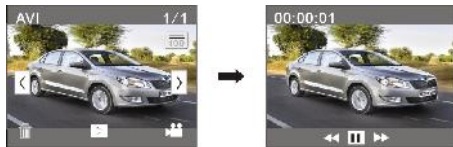

Presione  para pausar, presione  para hacer una búsqueda rápida.

9.3 Suprimir archivos:

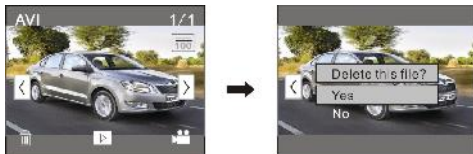

Presione YES para suprimir el archivo, presione en NO para anular la supresión.

Conectar la cámara a su ordenador

La cámara viene con la función plug-and-play. Conecte el periférico al ordenador con el cable USB en estado de marcha, la cámara cambiará automáticamente al modo disco duro amovible.

El ícono de disco amovible aparece en « ordenador ». Sus fotos/vídeos están guardados en la carpeta I:\DCIM\100MEDIA. Los archivos grabados en modo a bordo están guardados en I:\DCIM\RECORDER.

SEGURIDAD AMBIENTAL



Este producto STOREX ha sido probado en laboratorio y es consecuente con las correspondientes Directivas de la Unión Europea para la calificación CE aplicable durante el periodo de mercadeo.



Se realizó un rastreo de todos los componentes de su producto STOREX. Esto nos mostró que el producto cumple con las Directivas Medio Ambientales (RoHS) en vigencia al momento de su lanzamiento.



Cuando se periodo de vida útil acabe, no arroje el producto a la basura, sino que llévelo con el encargado de la eliminación de sus residuos domésticos. Este último introducirá al producto en un centro de reciclaje de basura electrónica y de mecanismos eléctricos y electrónicos (DEEE).

REGISTRO DE LA GARANTIA

En caso de que contacte a nuestro equipo de soporte, y para facilitar el manejo de su problema, lo invitamos a registrar la garantía del producto en nuestro sitio web en la siguiente dirección:

<http://garantie.storex.eu>

Contacte a su distribuidor para reparar su producto bajo garantía, o envíe su solicitud vía correo electrónico a la siguiente dirección:

support@storex.eu

o por teléfono a:

Francia: 01 55 85 82 00 (tarifa telefónica local a Paris).

España: 902 110 572 (soporte.es@storex.eu)

Portugal: 707 20 14 20 (apoio.pt@storex.eu)

Inglaterra: support.uk@storex.eu

X'TREM 

by



STOREX



Guia de utilização

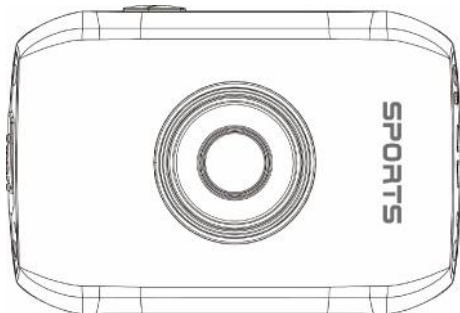

CSD123

ACESSÓRIOS DE MONTAGEM



Estojo à prova
de água



Suporte para
motos



Proteção



Suporte para
capacetes



Carregador



Bande velcro



Suporte com
ventosa

Fixação para moto



Fixação para capacetes

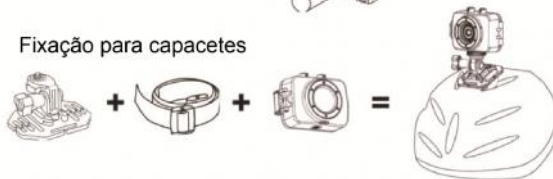

Suporte para carro



INFORMAÇÕES

- ◆ Por favor, leia cuidadosamente as informações antes de usar esta câmara de vídeo para um funcionamento adequado e seguro.
- ◆ Não exponha a câmara de vídeo a luz do sol diretamente, não aponte a lente à luz solar. Caso contrário, o sensor de imagem da câmara pode ser danificado.
- ◆ Cuidar bem da câmara de vídeo e evitar que a água ou partículas de areia entrem na câmara de vídeo quando ele é usado na praia.
- ◆ Manter a câmara de vídeo sem poeiras. Coloque-a em um lugar seco e bem ventilado. Não coloque a câmara de vídeo em alta temperatura, local húmido ou empoeirado.
- ◆ Por favor, verifique se a câmara de vídeo pode operar normalmente antes do uso.
- ◆ Se a sujeira é acumulada na câmara de vídeo ou na sua lente, use pano macio, limpo e seco para limpar suavemente. Se a câmara de vídeo ou a lente tem partículas de areia, limpe suavemente.
- ◆ Se for necessário limpar a superfície da câmara, em primeiro lugar, sobre a poeira acumulada sobre a superfície e, em seguida, limpe a câmara suavemente com o pano ou tecidos específicos aos equipamentos óticos. Por favor, use o agente de limpeza da câmara de vídeo para limpeza se necessário. Não use solventes orgânicos para limpar a câmara de vídeo.

- ◆ Não toque a superfície da lente com os dedos.
- ◆ Por favor, faça backup dos dados, se o cartão de memória dentro desta câmara de vídeo é usado pela primeira vez.

Os dados podem ser perdidos nas seguintes circunstâncias:

1. Uso não apropriado do cartão de memória.
2. O cartão de memória caiu, foi dobrado ou danificado.
3. O cartão foi colocado sob alta temperatura ou ambiente húmido.
4. Campos eletrostáticos ou campos eletromagnéticos em torno do cartão de memória.
5. Cartão de memória é retirado quando a câmara de vídeo ou computador está conectado para o cartão de memória (ou seja, durante a leitura, escrita e formatação).
6. Tocar a superfície de contato de metal do cartão de memória com os dedos ou materiais metálicos.

UTILIZAÇÃO DA BOX IMPERMEÁVEL

- ◆ Antes de fechar a box impermeável, manter limpo. Um único fio, cabelo ou um grão de areia pode causar um vazamento de vedação de borracha. Pode testar, fechando a box sem inserir a câmara. Mergulhe a box completamente na água cerca de um minuto. Retire a box da água, seque com uma toalha, em seguida, abra a caixa. Se todo o interior está seco, pode então utilizar a box para uso submarino.
- ◆ Lembre-se de colocar o interruptor de modo na posição desejada de gravação antes de inserir a câmara na box impermeável. Não há nenhum botão externo para mudar de modo.
- ◆ Após cada uso em água salgada, precisará de enxaguar a box com água. Se não pode eventualmente causar corrosão da dobradiça e acúmulo de sal na borracha.
- ◆ Para limpar a borracha, enxaguar em água. Reinstale a borracha nas ranhuras da carcaça.

DETALHES DA CÂMARA

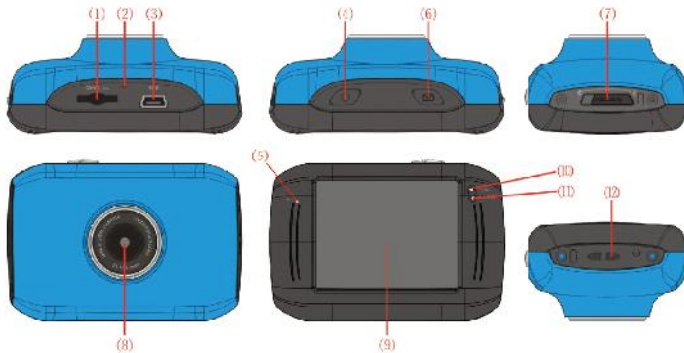

- (1) Ranhura cartão de memória
- (2) Reset
- (4) USB
- (5) On/Off
- (6) MIC
- (7) Prender foto

- (7) Modo Switch:
- (8) Lente
- (9) LCD TFT
- (10) LED Indicadora
- (11) LED indicadora de carga
- (12) Ranhura para fibela

UTILIZAÇÃO

1. Carregar a bateria



Conecte a câmara de vídeo ao computador para carregar. O indicador luminoso de carga será desligado após o carregamento. Em geral, o carregamento leva 2-4 horas.

2. CARTÃO DE MEMÓRIA

1. Empurre o cartão de memória no slot de cartão até que ele esteja completamente inserido.
2. Para tirar o cartão de memória, pressione suavemente o cartão de memória.

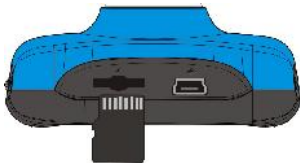

Nota: Nenhuma memória interna está disponível nesta câmara de vídeo. Certifique-se de inserir o cartão de memória antes de usar.

3. LIGAR/DESLIGAR

3.1 Ligar: Pressione o botão POWER por 3 segundos, a câmara irá acender.

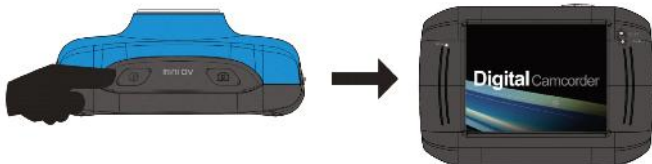

3.2. Desligar: Pressione o botão POWER, a câmara apagar-se-á.

Desligamento automático: quando a câmara atinge o tempo de desligamento automático, ela apagar-se-á automaticamente para economizar energia. O tempo desta câmara para desligamento automático é 5 minutos.

3.3. Desligamento em caso de falta de energia: quando a energia da bateria é insuficiente, a tela de LCD exibirá o ícone de baixa potência. Quando o indicador fica vermelha e pisca, a câmara de vídeo apagar-se-á automaticamente.

4. TROCAR ENTRE OS DIFERENTES MODOS

Três modos estão disponíveis para esta câmera de vídeo, ou seja, imagens, modo de gravação de vídeo e modo embarcado.

Modo Fotos: Para tirar fotos;

Modo Vídeo: Para gravar vídeos;

Modo Embarcado: Para gravar um vídeo (uma secção todos os 5 minutos)

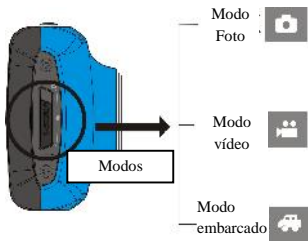

5. LUZ INDICADORA

Ocupado: quando a câmara está ocupada (por exemplo, a filmar ou tirar fotografias), a luz ocupada estará acesa.

Carregamento: Quando a luz está acesa por muito tempo, deverá carregar a câmara.

6. MODO GRAVAÇÃO VÍDEO

Quando o seletor de modo está ativado para o modo de gravação de vídeo, prima o botão do obturador uma vez, ou clique no centro do LCD uma vez para iniciar a gravação. Prima o botão do obturador novamente se quiser parar a gravação, a câmara vai parar a gravação automaticamente quando o cartão de memória está cheio ou a carga é insuficiente.

1 **00:12:18:** Significa que a gravação de vídeo ainda pode durar 12 minutos e 18 segundos.

2  : Representa que a câmara está no modo de gravação de vídeo.





3  : Resolução do vídeo, carregue nesse ícone para escolher 720p/VGA.

4  : Significa que o cartão de memória está inserido.

5  : Zoom digital, carregue para aumentar.

6  : Zoom digital, carregue para diminuir.





- 7  : Visual do obturador, toque o quadro visível para tirar fotografias ou gravar.
- 8  : Ícone de bateria, representa o estatuto de energia da bateria.
- 9  : Representa o estatuto do zoom digital.
- 10  : Carregue neste ícone para lançar o modo leitura.
- 11  : Clique neste ícone para definir a data e tempo, pressione a tecla do obturador para confirmar.

7 MODO FOTO:

Pressione o botão do obturador ou clique no centro do LCD para tirar uma foto:

1 **0/1234**: Contador, indicando o número atual de fotos tomadas/números de fotos a serem tomadas.

2  : Representa que a câmara está no modo de tiragem de fotos.

3  : Resolução da foto, carregue para modificar a resolução.

4  : Significa que o cartão de memória está inserido.

5  : Zoom digital, carregue para aumentar.

6  : Zoom digital, carregue para diminuir.

7  : Visual do obturador, toque o quadro visível para tirar fotografias ou gravar.

8  : Ícone de bateria, representa o estatuto de energia da bateria.

9 **1.00** : Representa o estatuto do zoom digital.

10  : Carregue neste ícone para lançar o modo leitura.

11 **SET** : Clique neste ícone para definir a data e tempo, pressione a tecla do obturador para confirmar.



8 MODO EMBARCADO:

Selecione o modo embarcado, pressionando o botão do obturador ou clicando no centro do LCD para começar a gravar, neste modo um é gravado um segmento cada 5 minutos. Quando o cartão de memória estiver cheio, o primeiro segmento de vídeo será suprimido para liberar espaço correspondente para gravação contínua.

1 **00:12:18**: Significa que a gravação de vídeo ainda pode durar 12 minutos e 18 segundos.

2  : Representa que a câmara está no modo de gravação de vídeo.

3  : Resolução do vídeo, carregue nesse ícone para escolher 720p/VGA.

4  : Significa que o cartão de memória está inserido.

5  : Zoom digital, carregue para aumentar.

6  : Zoom digital, carregue para diminuir.

7  : Visual do obturador, toque o quadro visível para tirar fotografias ou gravar.

8  : Ícone de bateria, representa o estatuto de energia da bateria.

9  : Representa o estatuto do zoom digital.









10  : Carregue neste ícone para lançar o modo leitura.

11  : Clique neste ícone para definir a data e tempo, pressione a tecla do obturador para confirmar.



9 MODO VISUALIZAÇÃO:

9.1 Após a inicialização entre no modo visualização, clique no ícone de reprodução () no canto inferior direito do LCD para alternar para o modo de reprodução:

- 1  : Representa que o arquivo atual é um arquivo de vídeo AVI.
- 2  : Representa o que há um arquivo na pasta atual / um arquivo no total.
- 3  : Nome da pasta atual (tais como: I:\DCIM\100MEDIA).
- 4  : Para selecionar o arquivo seguinte.
- 5  : Para selecionar o arquivo anterior.
- 6  : Para suprimir o arquivo selecionado.
- 7  : Para lançar a reprodução do ficheiro selecionado.
- 8  : Significa que pode alternar entre o modo de foto e vídeo.



9.2 Reprodução de um vídeo:



Carregue  para pausar, carregue  para efetuar uma pesquisa rápida.

9.3 Suprimir um ficheiro:

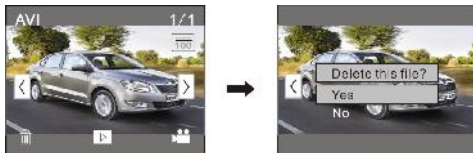

Carregue YES para suprimir o ficheiro selecionado, ou selecione NO para cancelar a supressão.

CONECTAR AO SEU COMPUTADOR

A câmara é fornecida com a função plug & play. Conecte o dispositivo ao computador com cabo USB em, de seguida, ele aparecerá como disco móvel.

Um ícone de disco móvel aparecerá no "meu computador". Fotos e vídeos que você tomou são salvos na pasta I:\DCIM\100MEDIA do disco móvel.

SEGURANÇA-MEIO AMBIENTE



Seu produto STOREX foi testado em laboratório e é coerente com as correspondentes diretivas europeias para a marcação CE em vigor durante o momento da comercialização.



Componentes do seu produto STOREX são rastreável; isso demonstra a conformidade do produto com as diretrizes ambientais (RoHS), em vigor à época de seu lançamento.



A rastreabilidade dos componentes do seu produto STOREX foi realizada; Isso mostra que o produto está em conformidade com a Directiva Ambiental (RoHS) em vigor à época de seu lançamento.

REGISTRO DE GARANTIA

A fim de facilitar a gestão do seu problema, deve entrar em contacto com a nossa equipe de apoio, nós convidamo-lo a registrar a garantia do seu produto em nosso site no seguinte endereço:

<http://garantie.storex.eu>

Para reparação, contacte o seu revendedor para reparar o seu tablet sob garantia, ou envie o seu pedido via e-mail para o seguinte endereço: support@storex.eu

ou por telefone:

França: 01 55 85 82 00 (custo da chamada local para Paris)

Espanha: 902 110 572 (suporte.es@storex.eu)

Portugal : 707 20 14 20 (apoio.pt@storex.eu)

Inglaterra : (support.uk@storex.eu)

X'TREM 

by



STOREX