

# STOREX



**UrbanRide**



## SECURITY INFORMATION

This product was designed and manufactured to ensure your safety. The security mechanisms incorporated in the product will protect you if you observe the following procedures for installation, use and troubleshooting: read carefully the following instructions and observe them before handling and installing your hardware. Save these instructions so that you can refer to later.

Before your starting, familiarize yourself with how to operation, so that you can keep the scooter in the best condition. Otherwise you will get crashed, fell down or lose control.

When you are learning the scooter, make sure that all safely measures are made. Like wearing a helmet, knee pads, elbow pads and other protective gears.

Self-balancing electric scooter is not allowed on the motor vehicle lanes.

Children, the elderly, pregnant women are not allowed to drive.

Do not drive after drinking or taking drugs.

Do not carry items when driving.

When driving the scooter, you should comply with local traffic laws, and give way to pedestrians.

Please be alert to things in front of you, maintain balance when encounter uneven ground.

In the process of driving, make ensure that the feet are always stepping on the mat.

Please wear appropriate clothes, this will help you to handle emergencies better.

Self-balancing electric scooter can only load one person, cannot load two people or more than two people.

Do not start or stop suddenly.

Avoid driving on steep slopes.

Do not drive in dimly lit or dark places.

## GENERALITIES

Do not shake the product under penalty of damaging it.

Use only parts and accessories (power supply...) specified by the manufacturer.

The illustrations of the product may vary from the actual product.

## SECURITY

To avoid fire or electric shock, do not place the appliance near objects filled with liquid. If a heavy object or liquid should fall on the device, have it checked by qualified personnel before using it again.

In operation, the surface of the housing gives off heat; therefore, do not cover it or put an object on it.



## POWER SUPPLY

The supplied power adapter is specific to the product. The use of a different adapter may damage the product or cause accidents.

## PRODUCT LOCATION

Install the unit away from any equipment to strong attraction such as microwave, large speakers...

## CLEANING

Never open the product to clean otherwise will void the warranty.  
Unplug the product from the wall outlet before cleaning the product.  
Clean the outside of the product with a soft, dry cloth. Never use abrasive cloth, scouring powder or solvent such as alcohol or gasoline.

## TROUBLESHOOTING

Refer all servicing to qualified personnel. Troubleshooting is necessary if the appliance has been damaged in any way: plug or power cord damaged, liquid spilled on the product, introduction of small objects in the product, exposure to rain or moisture, malfunctions, dropping the product...

## SECURITY – ENVIRONMENT

Your STOREX product has been tested in the laboratory; It is complies with the European directives for CE marking in force at the time of its marketing.

Traceability of the components of your STOREX product has carried out; she showed us the conformity of the product with environmental directive (ROHS) in force at the time of its marketing.

At the end of life, do not dispose in the garbage but bring to your site who will move the product in a chain of electrical, electromechanical and electronic waste (WEEE) recycling.



## PRODUCT PRESENTATION AND DETAILS

It possesses fashionable appearance, simple operation, easy to control, low-carbon and environment protection.



- 1- Engine brake
- 2- Charging connector
- 3- Accelerate
- 4- Monitor

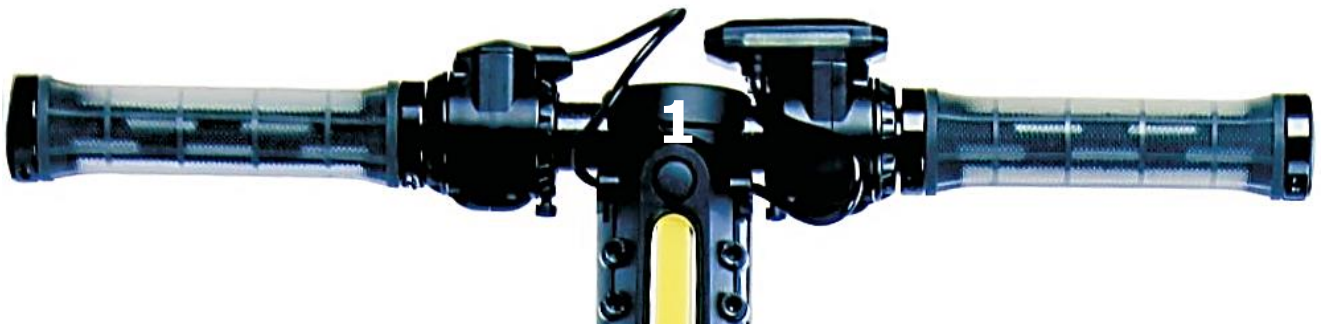

- 1- LED Light





## USING MONITOR

Short press on switch button:

- **VOL:** Battery charging level.
- **ODO:** Total mileage (long press to reset).
- **RPM:** Rotation per minute.
- **TIME:** Total time elapsed.

Long press on switch key:

- Turn On/Off the monitor.

## MOUNT THE HANDLEBAR

1. Insert the handlebar on top of the product.



2. Insert the following elements each side of handlebar.



## FINAL RESULT



### **FOLD THE PRODUCT**

1. Press the spring.
2. Lift up the base or low down the carbon tube to the base.
3. You will hear a click when the product is correctly folded.

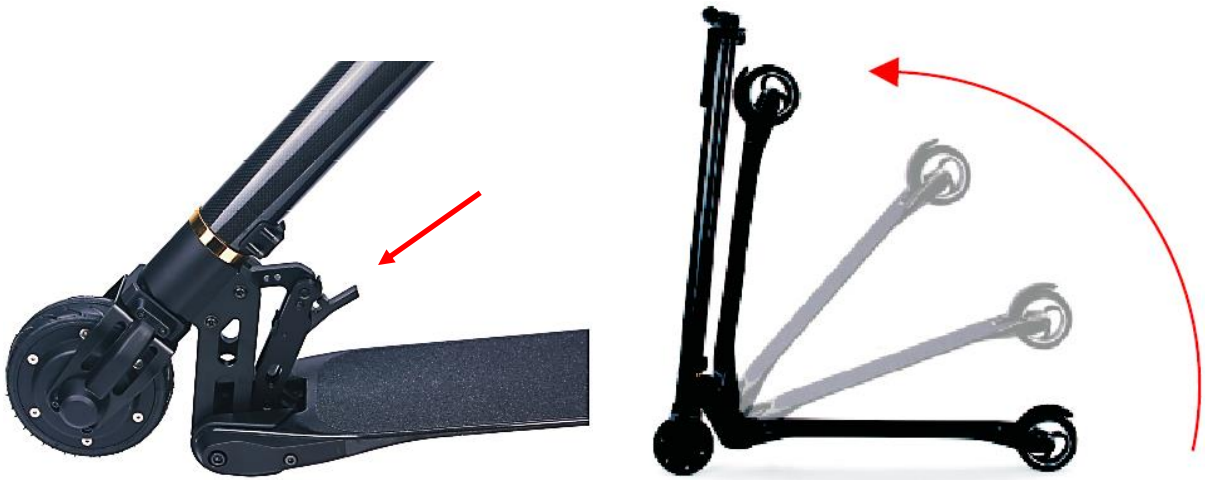

### **UNFOLD THE PRODUCT**

1. Press the spring.
2. Low down the base or loft up the carbon tube.
3. You will hear a click when the product is correctly folded.



## HOW TO USE

Position yourself on the basis of the product, give a slight pulse forward and press the accelerator in order to initiate the engine.

Press harder on the accelerator to increase the speed.

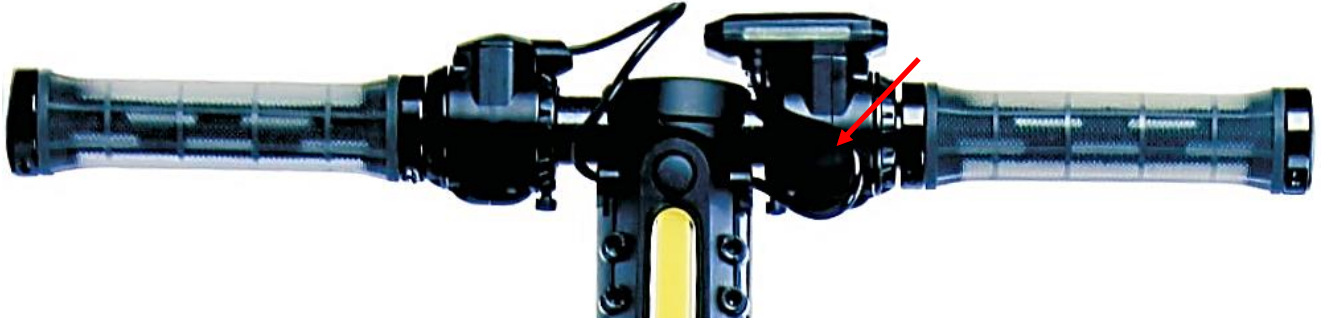

Press the engine brake to slow down or press the rear wheel to brake manually.

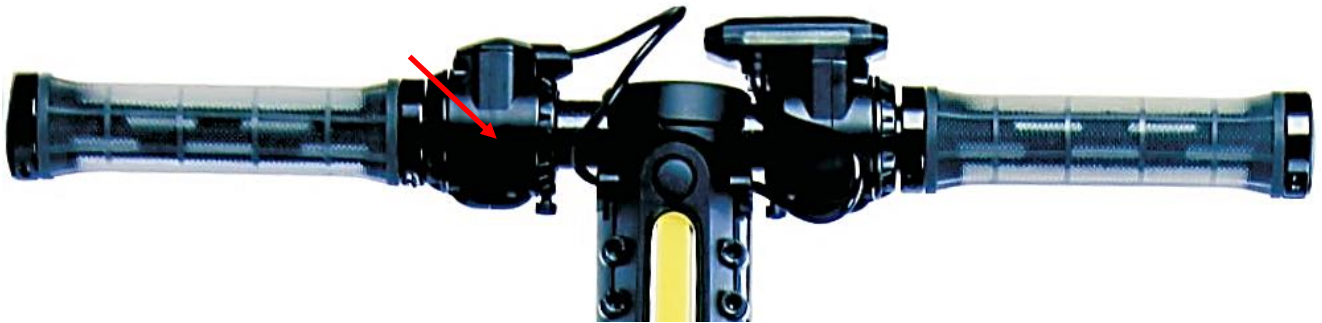



<b>SPECIFICATIONS</b>		
<b>Net Weight</b>	6,5KG	
<b>Minimum Load</b>	20KG	
<b>Maximum Load</b>	90KG	
<b>Maximum Speed</b>	12-23KM/H	Distance Various depending on terrain, driving style and load
<b>Range Per Charge</b>	19 - 28KM	Depending on the load
<b>Climbing Capacity</b>	20°	
<b>Energy</b>	Rechargeable Li-ion Battery	
<b>Charger Voltage</b>	100-240V 50-60 HZ	
<b>Dimension folded (mm)</b>	1000 x 405 x 235	
<b>Dimension unfolded (mm)</b>	920 x 405 x 1000	



## GUARANTEE CONDITIONS

**STOREX**'s available guarantee is valid for 2 year for your product and 3 months for its accessories (power supply, cables...).

**STOREX** guarantees your products against any manufacturing or assembling faults. This guarantee only applies to the first purchase of your product by the end user and is not transferable if the device is resold. This warranty does not cover any incompatibilities found by end user apart from recommendations specified on the packaging, or any other incompatibility generated by other hardware or software on the computer that is connected to the your product.

Proof of purchase must be presented to our services to apply **STOREX** guarantee.

The guarantee doesn't cover failures or defects induced by non-compliance to this manual's instructions, neglect, alteration, improper installation or maintenance, reparation or alteration not authorized by **STOREX**, improper tests, accident or external factor such as (not exhaustive) excessive heat or dampness, power failures or bad installation / uninstalling of your product.

The only contractual obligation endorsed by **STOREX** pertains to the reparation or replacement of a defective product. In no case, **STOREX** cannot be held responsible for any loss of data, or its consequences induced by operational fault or a product failure. In any case, **STOREX** won't be bound to any financial responsibility for any amount exceeding the value of the product purchased by the end user.

This guarantee is well defined and cannot be modified, decreased or increased without written consent from **STOREX**. In addition, **STOREX** cannot be held responsible for any technical advice or service provided in relation to your product.

For any request not covered by this guarantee, please contact **STOREX** support or log on to [www.e-storex.com](http://www.e-storex.com) to order accessories.

You are not the grantee of this current warranty. This warranty covers only your product and is governed by French law.

**Note:**

**STOREX**™ reserves the right to modify the user manual without prior notice according to the product's evolutions. You can find the latest version of the manual on our website: <http://www.storex.eu>



## STOREX WEBSITE

Please visit our website: <http://www.storex.fr>.

## GUARANTEE REGISTRATION

To facilitate your support during any call with our support team, we invite you to register the warranty of your product on our Web site at the address:

<http://garantie.storex.eu>

In case of failure, please contact STOREX support to repair your product under warranty, or please send your request by e-mail to the address:

[support@storex.eu](mailto:support@storex.eu)

or by phone at

**France:**           **01 55 85 82 00** ([support.fr@storex.eu](mailto:support.fr@storex.eu))

**Portugal:**       **308 800 836** ([apoio.pt@storex.eu](mailto:apoio.pt@storex.eu))

**Spain:**           **902 110 572** ([soporte.es@storex.eu](mailto:soporte.es@storex.eu))

**England:**       ([support.uk@storex.eu](mailto:support.uk@storex.eu))

From Monday to Thursday - 09h30 at 19h30.

Friday - 9h30 at 18h30.

 **STOREX**

CE